

Quality Issues in Radar Wind Profiler

C. Abhishek

B.Tech (ECE) Student
Electronics And Communication Engineering
SCSVMV University Kanchipuram

P. Nikitha Reddy

Electronics And Communication Engineering
SCSVMV University Kanchipuram

Abstract

The paper discusses possible quality issues of operational radar wind profilers (RWP). Ground-based remote measurements of the vertical profile of the horizontal wind vector in the atmosphere by radar wind profiler (RWP) are a technique that has been significantly. The main advantage of RWP's is their ability to provide vertical profiles of the horizontal wind at high temporal resolution under almost all weather conditions that is in both the cloudy and the clear atmosphere.

Keywords: Radar, Wind, RWP, Doppler, Beam Swinging

I. INTRODUCTION

A wind profiler is a type of weather observing equipment that uses radar or sound waves (SODAR) to detect the wind speed and direction at various elevations above the ground. Readings are made at each kilometer above sea level, up to the extent of the troposphere (i.e., between 8 and 17 km above mean sea level). Above this level there is inadequate water vapor present to produce a radar "bounce." The data synthesized from wind direction and speed is very useful to meteorological forecasting and timely reporting for flight planning. In a typical implementation, the radar or sodar can sample along each of five beams: one is aimed vertically to measure vertical velocity, and four are tilted off vertical and oriented orthogonal to one another to measure the horizontal components of the air's motion. A profiler's ability to measure winds is based on the assumption that the turbulent eddies that induce scattering are carried along by the mean wind. All these systems works on back ray scattering principle. The energy scattered by these eddies and received by the profiler is orders of magnitude smaller than the energy transmitted. However, if sufficient samples can be obtained, then the amplitude of the energy scattered by these eddies can be clearly identified above the background noise level, then the mean wind speed and direction within the volume being sampled can be determined.

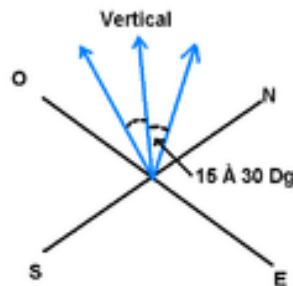

Fig. 1: Orientation of Beams In Wind Profiler

The radial components measured by the tilted beams are the vector sum of the horizontal motion of the air toward or away from the radar and any vertical motion present in the beam. Using appropriate trigonometry, the three-dimensional meteorological velocity components (u , v , w) and wind speed and wind direction are calculated from the radial velocities with corrections for vertical motions. For ground based remote sensing systems, RWP are among the most thoroughly developed and widely used sensors. As the name implies, they are special Doppler radars designed for measuring the vertical profile of the wind vector in the lowest 5 - 20 km of the atmosphere (depending on the operating frequency) on timescales ranging from minutes to years. RWP's are furthermore able to provide additional information about the atmospheric state through the profiles of backscattered signal intensity and frequency spread (spectral width) of the echo signal. If the RWP system is equipped with an additional Radio-Acoustic Sounding System (RASS) component, then measurements of the vertical profile of the virtual temperature are also possible. Due to the high temporal resolution of RWP observations, the data are especially well suited to describe the atmospheric state at the meso scale the dramatic rise in computational capabilities during the last decades has led to significant improvements in the discretization resolution of NWPM. Global models are meanwhile using grid spacing's, while high-resolution limited area models already use grid sizes of 1km in an attempt to resolve small-scale meteorological processes.

A necessary prerequisite must be followed for successful operational application of RWP is that the instruments must be able to provide high-quality measurements in an operational, fully automated fashion. This seemingly trivial requirement is indeed somewhat difficult to achieve, for the required high sensitivity of the radars make them vulnerable to unwanted and potentially

quality-degrading effects ,like echoes from various clutter sources and radio-frequency interference. In particular, the automated data processing must be capable of sufficiently suppressing these clutter effects.

II. RADAR HARDWARE

RADAR means radio detecting and ranging, this is the most important device in navigation and remote sensing. It consists of transmitter, receiver and a mixer. The signal that is to be transmitted is given to the antenna and the reflected signal is received by the same antenna. By using same antenna for transmission and reception efficiency will be more and also it the size of the radar will be less. RADAR works on Doppler effect principle, the signal is transmitted towards the target with the transmitting antenna, the signal will be reflected when it strikes the target, the reflected signal is received by the same antenna, difference between the transmitted and reflected frequencies is calculated and Doppler shift is obtained

Fundamental aspects for a general discussion of potential RWP quality issues it is useful to briefly review both the physical fundamentals and the technical constraints of these instruments. Radar hardware Depending on their particular hardware architecture, RWP can be classified into three main groups. Single signal systems are monostatic pulse radars using one single carrier frequency, with the hardware architecture resembling that of a typical Doppler radar system. The term single signal refers to the characteristics of the instruments sampling function, which can be regarded as an integral kernel function that maps a field describing the physical properties of the atmosphere relevant for the actual scattering process to the received radar (voltage or current) signal.). The general hardware architecture of RWP is shown in the simplified block diagram, see Fig. 2.

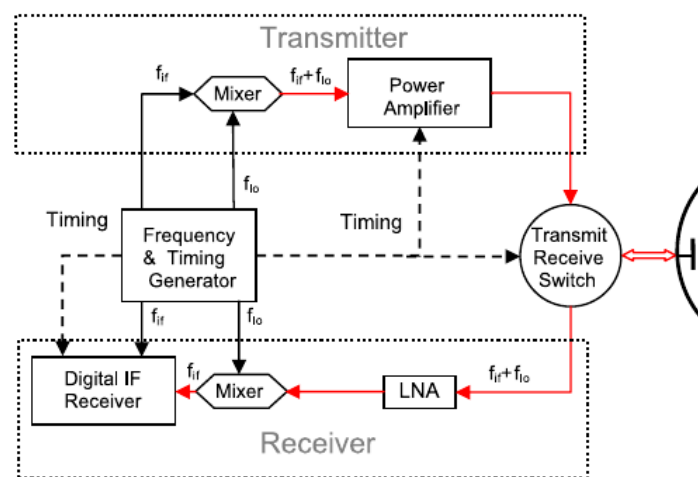

Fig. 2: Simplified Block Diagram of RWP

The central unit is the radar controller, which uses a highly stable oscillator (coherent oscillator or COHO) as the single reference for all signals and is activated by the radar processor. The signal to be transmitted is generated by a waveform generator which can be looked at as an amplitude and phase modulator. After up-conversion and amplification (power amplifier) the transmit signal is delivered to the antenna. A duplexer allows the use of a single antenna for transmitting and receiving. It is often comprised of solid-state ferrite circulator and additional receiver protecting devices. The antenna is typically an electronically steered phased array. Both active and passive arrays are used, with the passive variant still being more widespread. Beam steering is obtained through a distinct phasing of the individual array elements. This is mainly achieved through either mechanically relay-switched or electronically switched true-time delay components. While most RWP are only capable of steering the beam into a few (3-5) directions.

A. RF Interference Profilers:

Radio frequency interference to profilers Radio frequency interference (RFI) to profilers is caused by all electromagnetic signals that are sufficiently strong to be detected by the profilers receiver and processing system. It is useful to discriminate between coherent interference and incoherent interference.

Coherent interference is any signal that will be interpreted by the profiler as a valid signal in its Doppler spectrum. This is the most disruptive to profilers operation, because it may wrongly be interpreted as a valid atmospheric signal. Incoherent interference in contrast is any signal that is not detectable as a distinct peak in the Doppler spectrum but raises the noise level of the system. This would not generate false estimates for atmospheric returns, but degrade the SNR and thus reduce the height coverage of the radar. Of course this means that the interfering signal is sufficiently wide-band to the frequency response of the profiler and has a "white" spectral structure. The effect of the additional noise contribution is a de-sensitization of the profiler which obviously leads to decreased height coverage. However, this reduction in height coverage is very difficult to quantify. The reason is the high dynamic range of volume reflectivity which accounts for the radar returns.

B. Signal processing:

The intention of RWP signal processing is to convert the measured electrical signal to meteorological parameters. Key aspects are to extract as much information as possible, with the specific purpose of obtaining accurate, unbiased estimates of the characteristics of the desired atmospheric echoes, to estimate the accuracy of the measurement and to mitigate effects of clutter or interfering signals. Obviously, the accuracy and precision of the final data is largely determined by the quality of signal processing. Due to the nature of the (theoretical) atmospheric backscattering, signal processing for RWP is largely build upon spectral estimation methods. A typical atmospheric signal achieves a sparse representation in Fourier space, meaning that it can be sufficiently described with only a few parameters. However, practical deviations from this assumption make additional processing steps necessary. In general, the following sequences of processing steps are applied to the RWP receiver signal:

- Demodulation, range gating and A/D conversion
- Digital pre-filtering
- Estimation of the Doppler spectrum
- Signal detection, classification and moment estimation
- Computation of the wind

C. Wind determination-Doppler Beam Swinging:

Single signal RWP uses the simple method of Doppler beam swinging (DBS) to determine the wind vector. At least three linear independent beam directions and some assumptions concerning the wind field are required to transform the measured 'line-of-sight' 'radial velocities into the wind vector. For a five beam system, the sampling configuration is illustrated in Fig. 8. Under the assumption that the wind field v is horizontally homogeneous in the area that is spanned by the oblique beams, the relation between the Cartesian wind field components (u, v, w) and the radial velocities measured by the profiler can be expressed through a system of linear equations

$$\begin{pmatrix} \sin(\alpha_1)\sin(\varepsilon_1) & \cos(\alpha_1)\sin(\varepsilon_1) & \cos(\varepsilon_1) \\ \sin(\alpha_2)\sin(\varepsilon_2) & \cos(\alpha_2)\sin(\varepsilon_2) & \cos(\varepsilon_2) \\ \sin(\alpha_3)\sin(\varepsilon_3) & \cos(\alpha_3)\sin(\varepsilon_3) & \cos(\varepsilon_3) \\ \sin(\alpha_4)\sin(\varepsilon_4) & \cos(\alpha_4)\sin(\varepsilon_4) & \cos(\varepsilon_4) \\ \sin(\alpha_5)\sin(\varepsilon_5) & \cos(\alpha_5)\sin(\varepsilon_5) & \cos(\varepsilon_5) \end{pmatrix} \begin{pmatrix} u \\ v \\ w \end{pmatrix} = \begin{pmatrix} vr_1 \\ vr_2 \\ vr_3 \\ vr_4 \\ vr_5 \end{pmatrix}$$

Where α_i and ε_i denote azimuth and elevation angles of beam i . In compact matrix notation, this can be written as

$$A_v = v_r$$

This over-determined system can be solved in a least-squares sense

$$|A_v - v_r|^2 \rightarrow \text{Min.}$$

So that the wind vector components can be obtained from the measured radial velocities through a pseudo-inverse as (the matrix superscripts T and 1 denote transposition and inverse, respectively):

$$v = (A^T A)^{-1} A^T V_r$$

III. CONCLUSION

Radar wind profiler is mostly used in meteorological purposes for finding the speed and different physical parameters of the wind. It has a lot of issues due to changes that occur in the atmosphere, by rectifying these issues, the efficiency of the radar will be high and accurate outputs can be obtained.

REFERENCES

- [1] Satoh, M., Matsuno, T., Tomita, H., Miura, H., Nasuno, T., and Iga, S., Nonhydrostatic icosahedral atmospheric model (NICAM) for global cloud resolving simulations, *J. Comput. Phys.*, 227, 3486–3514, 2008.
- [2] Schmidt, G., Rüster, R., and Czechowsky, P., Complementary code and digital filtering for detection of weak VHF radar signals from the Mesosphere, *IEEE Trans. Geosci. Electron.*, GE-17, 154–161, 1979.
- [3] Scipion, D. E., Chilson, P. B., Fedorovich, E., and Palmer, R. D., Evaluation of an LES-based wind profiler simulator for observations of a daytime atmospheric convective boundary layer, *J. Atmos. Oceanic Technol.*, 25, 1423–1436, 2008.
- [4] Woodman, R. F., Spectral moment estimation in MST radars, *Radio Sci.*, 20, 1185–1195, 1985.
- [5] Wuertz, D. B., Weber, B. L., Strauch, R. G., Frisch, A. S., Little, C. G., Merritt, D. A., Moran, K. P., and Welsh, D. C., Effects of precipitation on UHF wind profiler measurements, *J. Atmos. Oceanic Technol.*, 5, 450–465, 1988.
- [6] White, A. B., Jordan, J. R., Martner, B. E., Ralph, F. M., and Bartram, B. W., Extending the dynamic range of an S-Band radar for cloud and precipitation studies, *J. Atmos. Oceanic Technol.*, 17, 1226–1234, 2000.
- [7] Zmí'c, D. S. and Doviak, R. J., Matched filter criteria and range weighting for weather radar, *IEEE Transactions on Aerospace and Electronic Systems*, AES-14, 925–929, 1978.
- [8] Wilfong, T. L., Merritt, D. A., Lataitis, R. J., Weber, B. L., Wuertz, D. B., and Strauch, R. G., Optimal generation of radar wind profiler spectra, *J. Atmos. Oceanic Technol.*, 16, 723–733, 1999.